



OPEN HAULERS

Aluminum Trailers

Got a car, truck or ATV to move? We can help!

SMOOTH LOADER

Car Hauler

Shown with Optional
Aluminum Deck



ART OATV

Open Quad

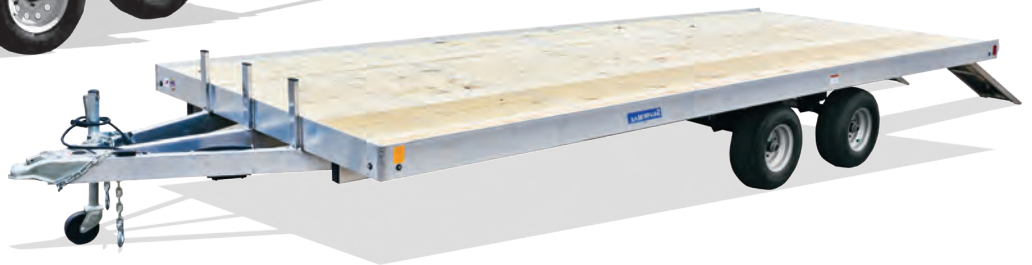

ARCH

Car Hauler

Tapered
Beavertail and
6' Long Ramps
Are Standard



OB1

Motorcycle Hauler



ARCHDO

Deck Over

8' Long Ramps
Are Standard



OB2

Motorcycle Hauler

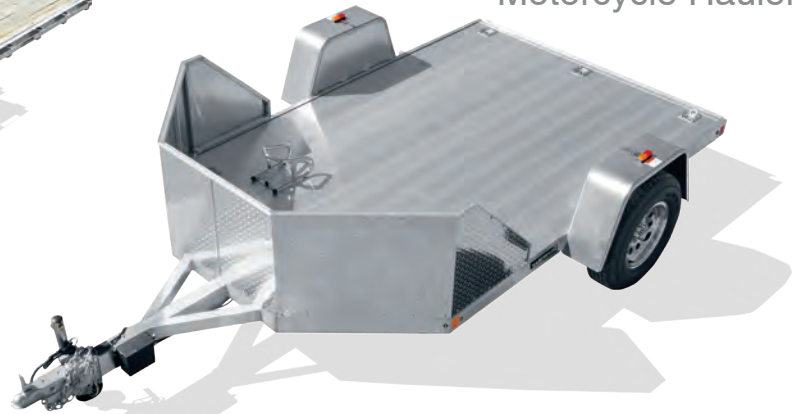



OPEN HAULERS

SMOOTH LOADER Car Hauler

2" Thick (nominal)
Pine Plank Treated Floor

Removable
Fenders

For fast and easy loading, nothing beats the RC Trailers sleek and powerful Smooth Loader.

The Smoothloader is available in a variety of configurations.

Choices Include

- Wood or Aluminum Bed
- 3500, 5200 or 6000 lb. Axles
- Manual Tilt or Electric Tilt
- Lengths From 18' to 24'

For the **Smooth Loader** and **ARCH Deck Over**, you can add **Heavy Duty D-Rings** for additional flexibility in securing your loads!

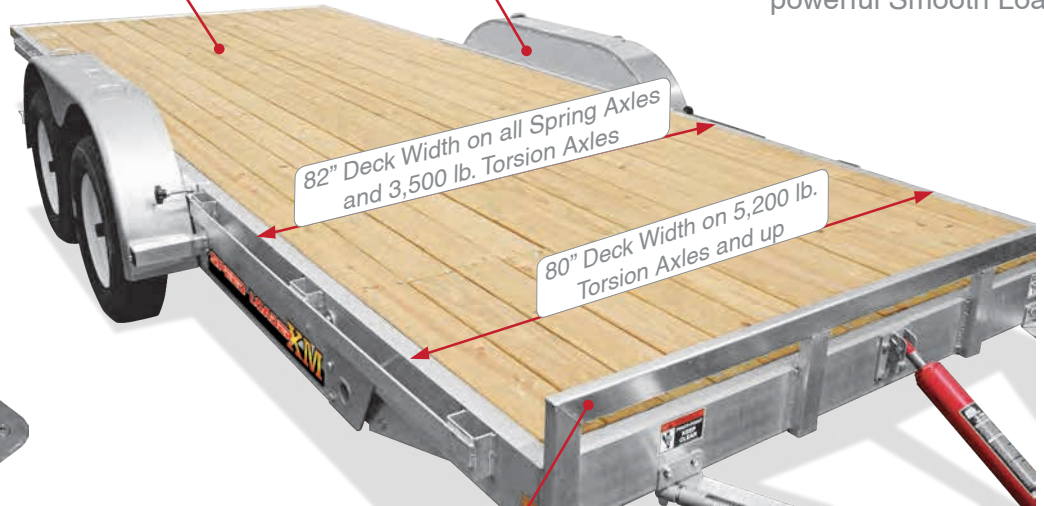

82" Deck Width on all Spring Axles and 3,500 lb. Torsion Axles

80" Deck Width on 5,200 lb. Torsion Axles and up

7" Tall Front Rail

TILT AND GO!

No ramps to hassle with!

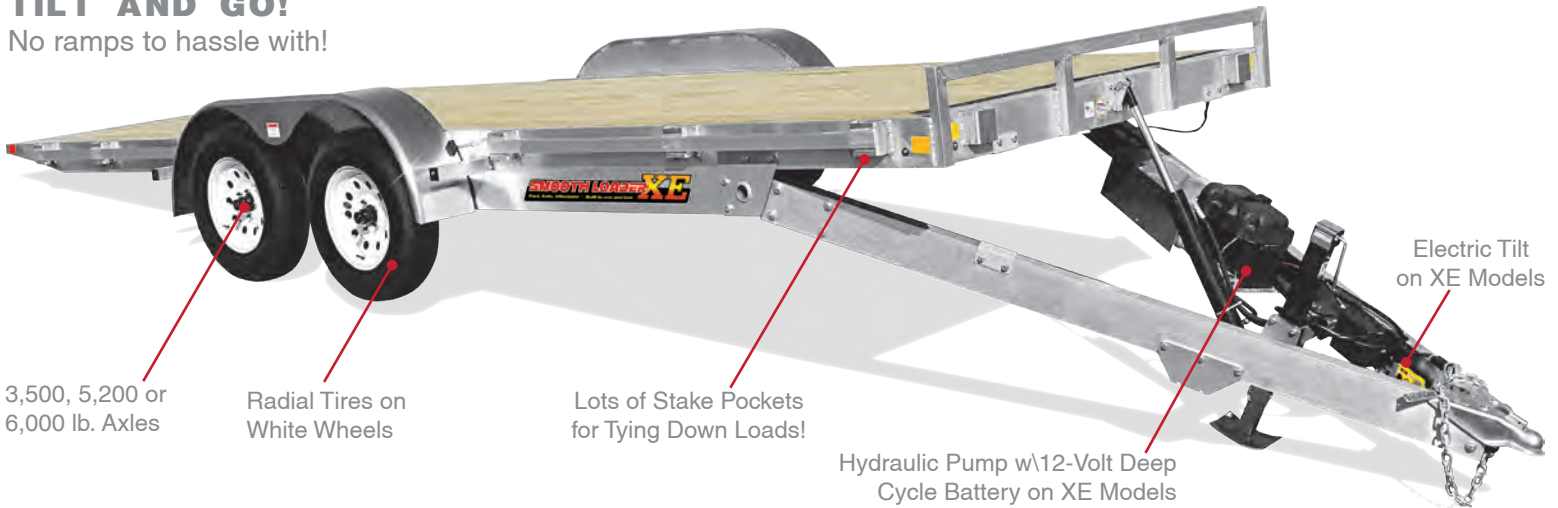

3,500, 5,200 or 6,000 lb. Axles

Radial Tires on White Wheels

Lots of Stake Pockets for Tying Down Loads!

Hydraulic Pump w/12-Volt Deep Cycle Battery on XE Models

Electric Tilt on XE Models

Optional Aluminum Deck

7,000 lb. Tongue Jack

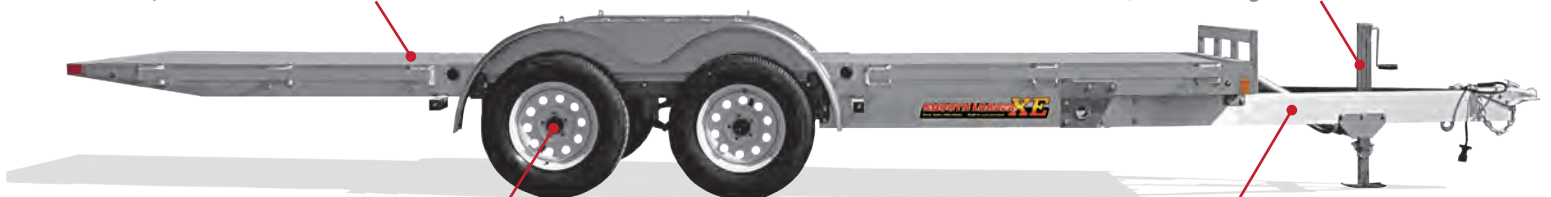

Spring or Torsion Axles

All Aluminum Frame Construction

SMOOTH LOADER

XM Model = MANUAL TILT
XE Model = ELECTRIC TILT

ARCH Car Hauler

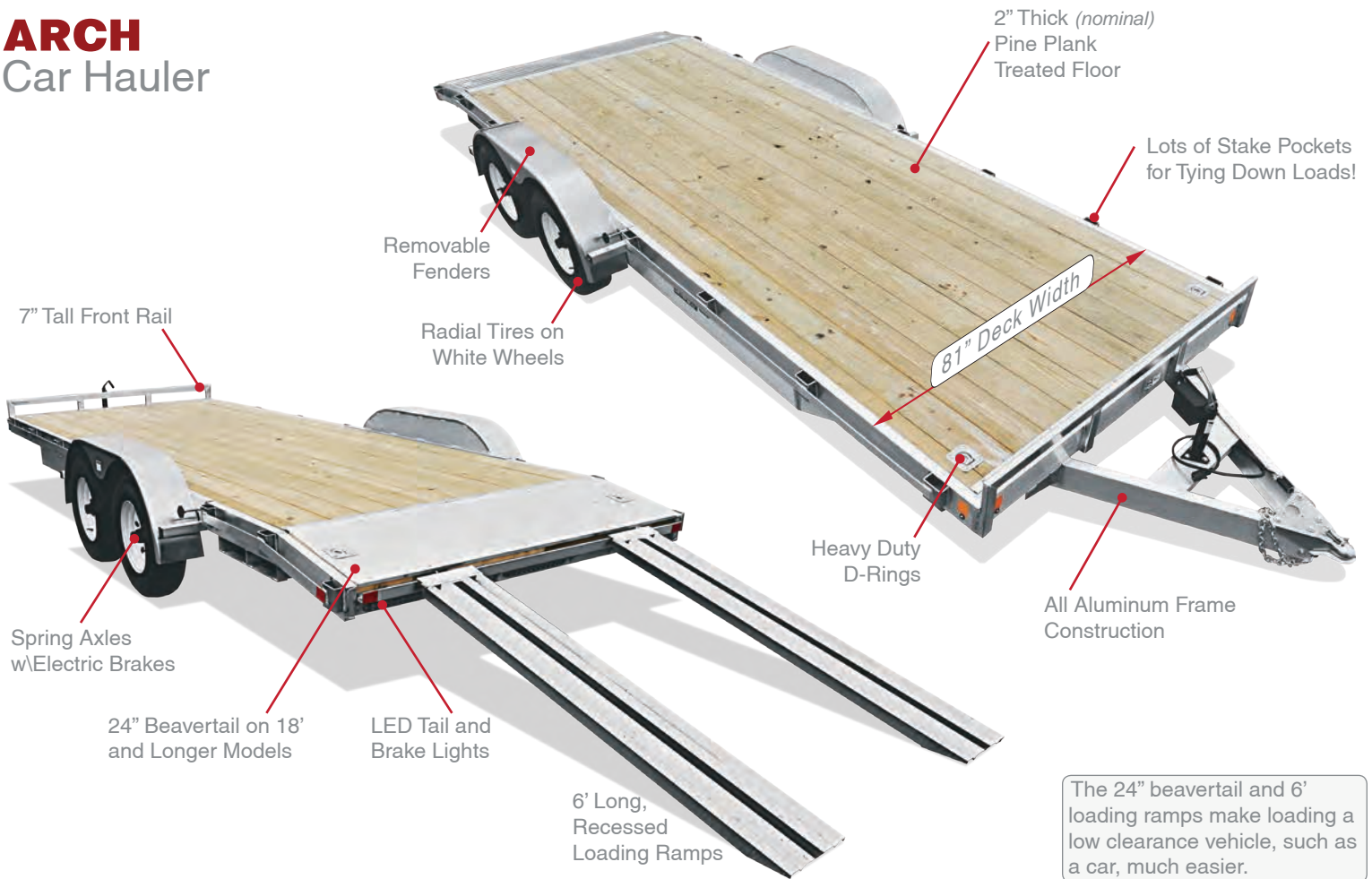

ARCHDO Deck Over

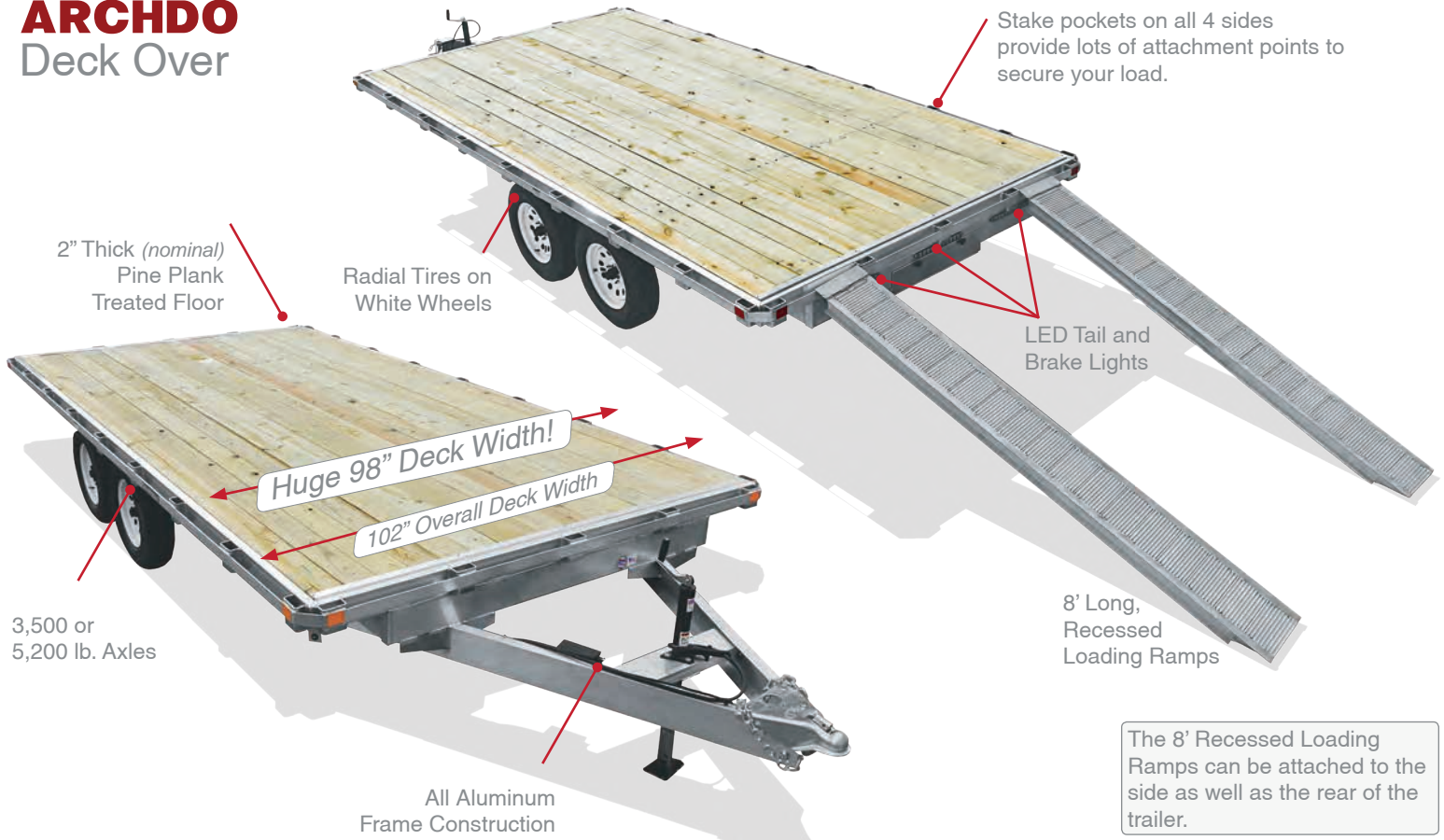

OB1 Motorcycle Trailer

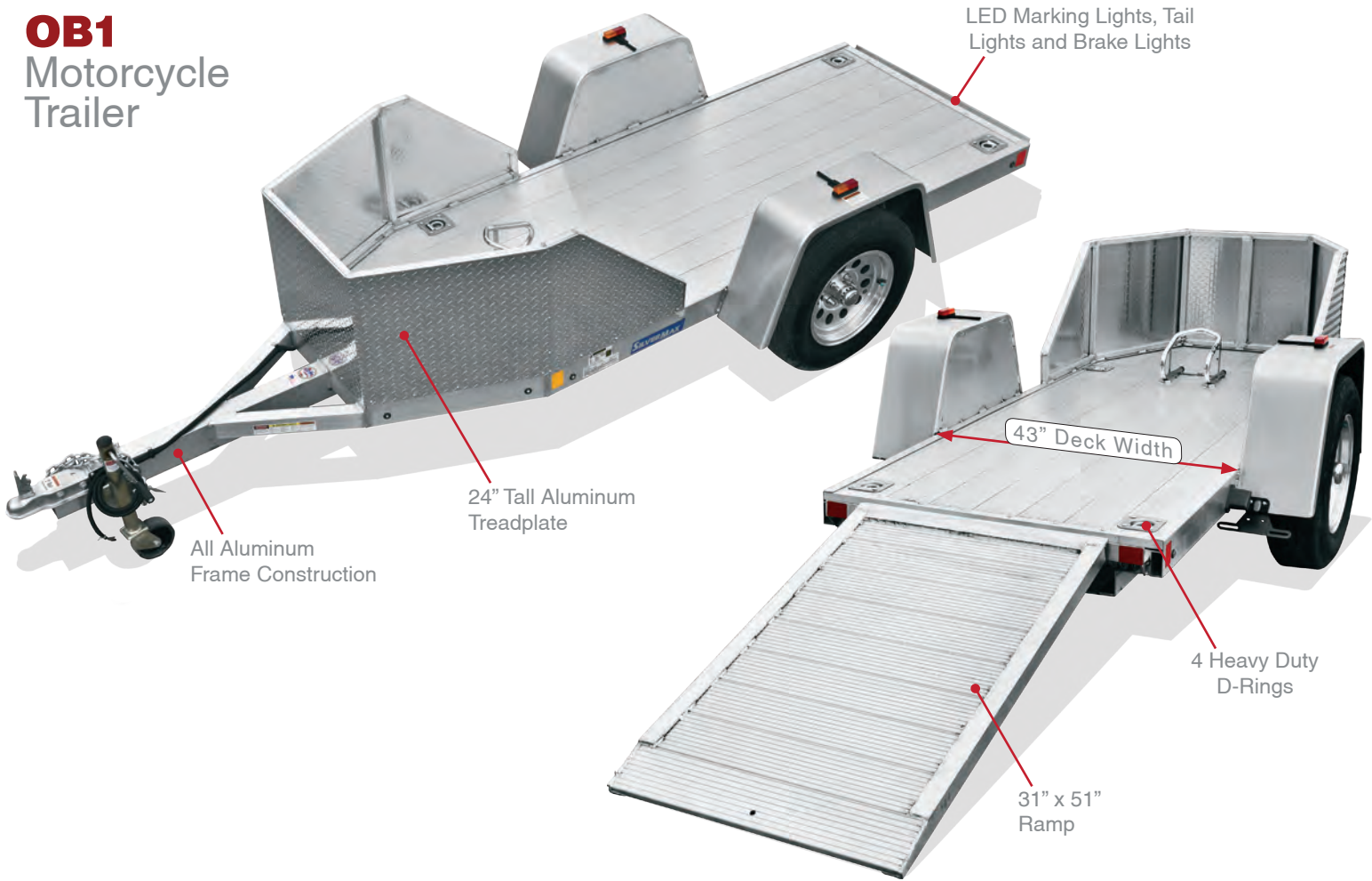

OB2 Motorcycle Trailer

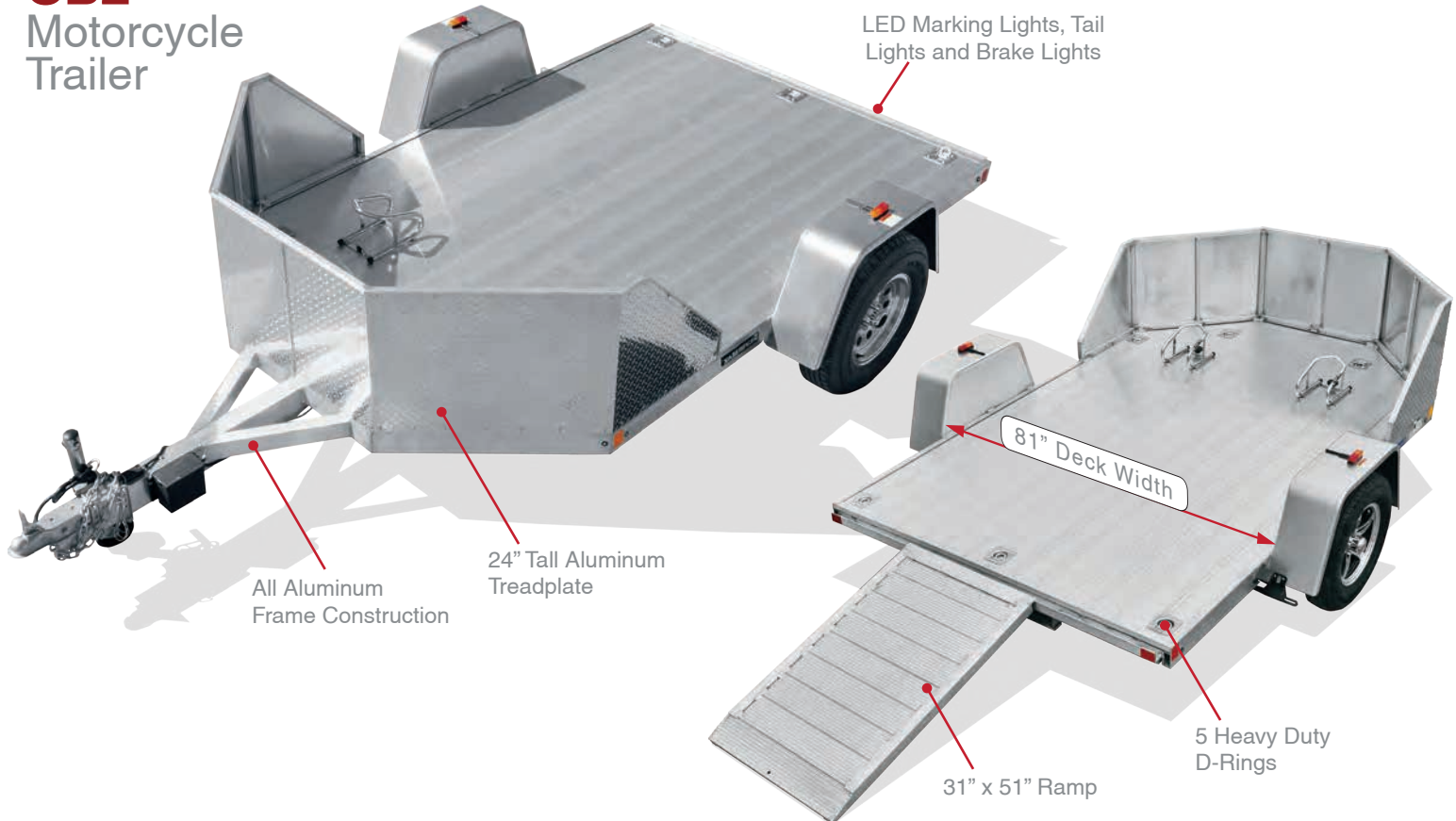

ART OATV

Open Quad Hauler

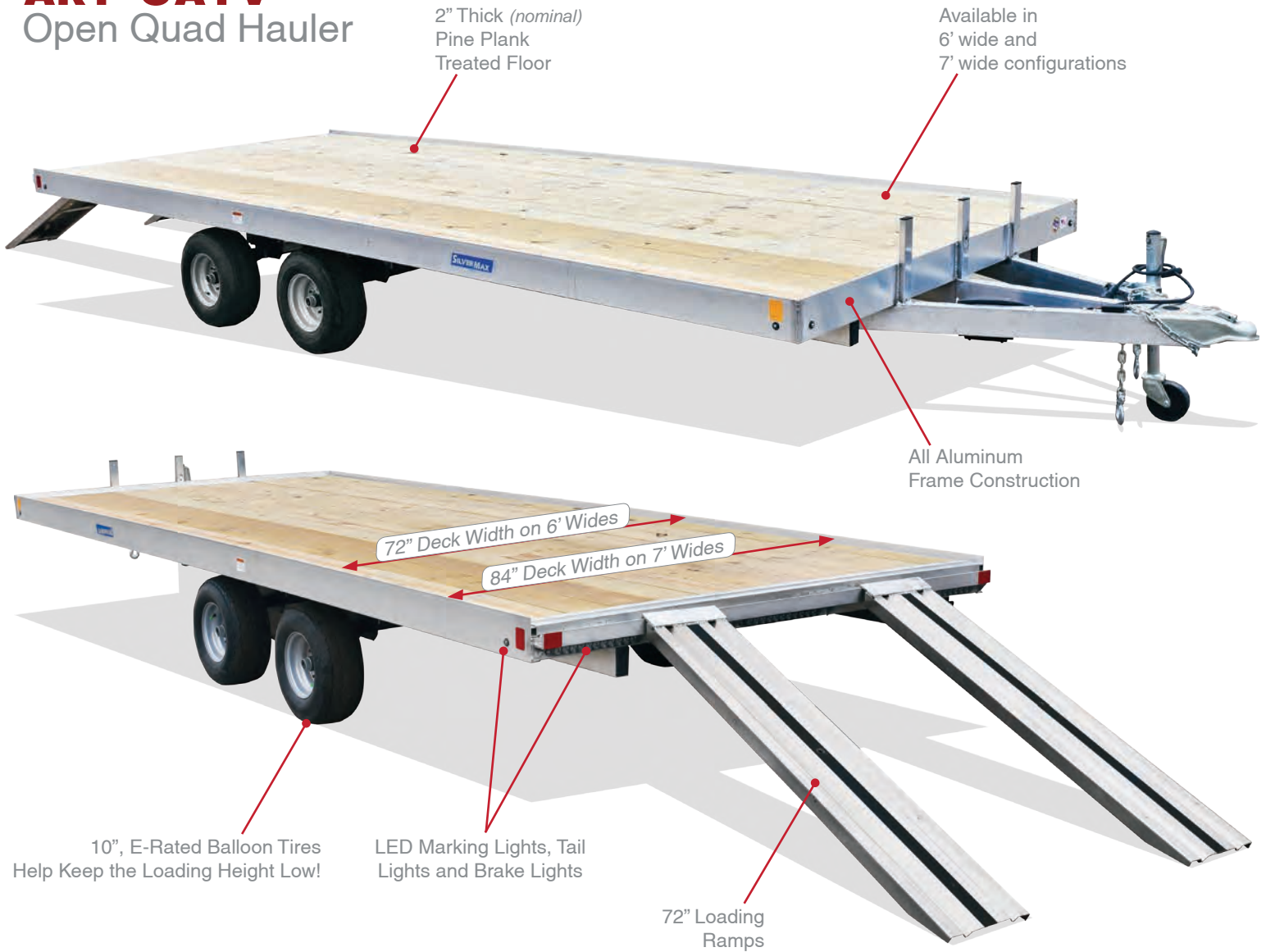

OPTIONAL WHEELS

Take your trailer to the next level with your choice of sporty wheels!



Aluminum Mod



Series 14

RC Trailers is a proud member of the National Association of Trailer Manufacturers



Standards and Specifications

	Smooth Loader XM	Smooth Loader XE	ARCH	ARCH Deck Over	OB1	OB2	ART OATV	
Hitch								
Coupler With Safety Chains	2-5/16"	2-5/16"	2-5/16"	2-5/16"	2"	2"	2" ⁴	
6" Underslung Tongue	No	No	No	Yes	No	No	No	
Tongue Jack or Front Jack Capacity	7,000 lb.	7,000 lb.	2,000 lb.	2,000 lb.	1,000 lb.	1,000 lb.	1,000 lb.	
Axle and Brakes								
Spring or Torsion Axles Depending	Either	Either	Spring	Spring	Torsion	Torsion	Torsion	
Electric Brakes	Yes	Yes	Yes	Yes	No	Yes	Some Models ³	
Tires and Rims								
20.5 X 8-10 LRE Bias Ply Tires	N/A	N/A	N/A	N/A	N/A	N/A	Yes	
ST205/75R15 C Rated Radial Tires For Single Axle	N/A	N/A	N/A	N/A	Yes	Yes	No	
ST205/75R15 C Rated Radial Tires For TA2 Axles	Yes	Yes	Yes	Yes	No	No	No	
ST225/75R15 D Rated Radial Tires For TA3 Axles	Yes	Yes	Yes	Yes	No	No	No	
ST235/80R16 E Rated Radial Tires For TA4 Axles	Yes	Yes	Yes	Yes	No	No	No	
Frame								
All Aluminum Frame Construction	Yes	Yes	Yes	Yes	Yes	Yes	Yes	
24" Beavertail on 18' and Longer Models	No	No	Yes	No	No	No	No	
7" Tall Aluminum Tube "Headache" Rack	Yes	Yes	Yes	No	No	No	No	
Heavy Duty D-Rings or Rope Ties	Opt	Opt	4 D-Rings	Opt	4 D-Rings	7 D-Rings	6 Rope Ties	
Stake Pockets with Rub Rail	Yes	Yes	Yes	Yes	No	No	No	
2" Thick (nominal) Pine Plank Treated Floor	Yes	Yes	Yes	Yes	No	No	Yes	
Extruded Aluminum Floor	Opt	Opt	Opt	Opt	Yes	Yes	No	
Exterior								
Deck Width	82"	82"	81"	98"	43"	81"	72" or 84"	
Deck Height (approximate) ¹	24" ²	24" ²	23" ²	33-1/2" ²	16-1/2"	16-1/2"	26-1/2"	
Removable Fenders	Yes	Yes	Yes	No Fenders	No	No	No Fenders	
Electrical								
LED Tail Lights, Brake Lights, and Marking Lights	•	•	•	•	•	•	•	
4-Way, or 7-Way Plug for 3,000 lb GVWR and up	•	•	•	•	•	•	•	
Breakaway Box, Battery and Switch	•	•	•	•	•	•	•	
Hydraulic Pump w/12-Volt Deep Cycle Battery	No	Yes	N/A	N/A	N/A	N/A	N/A	

¹ For general reference only. Deck heights will vary depending on axle capacity, axle type and tire sizes.

² For models with TA2 axles (Tandem 3,500 lb. axles)

³ Yes, on Tandem Axle Models

⁴ 2-5/16" on Tandem Axle Models

Available Sizes			
	TA2	TA3	TA4
Smooth Loader XM (Manual) or XE (Electric)			
18'	•	•	•
20'	•	•	•
22'	•	•	•
24'	•	•	•
ARCH - Car Hauler			
18'	•	•	•
20'	•	•	•
22'	•	•	•
24'	•	•	•
ARCHDO - Deck Over			
16'	•	•	
18'	•	•	
20'	•	•	

Available Sizes		
	Single Axle	Tandem Axle
OB1 & OB2 - Motorcycle Trailers		
4.5'x10' OB1	•	
8.5'x11' OB2		
ART OATV - 6' Wide, 7' Wide		
6'x8'	•	
6'x10'	•	
6'x12'	•	•
6'x14'		•
6'x16'		•
7'x12'		•
7'x14'		•
7'x16'		•
7'x18'		•



3-year Limited Warranty.
See your dealer for details!

Your Professional RC Trailers Dealer is:

